

# EasyChef XL

## USER MANUAL

7.5L Air Fryer with 360° Airflow Technology & Digital Touch Control



**7.5L**  
Extra-Large  
Capacity

**360°**  
Air-Flow  
Technology

**1700W**  
Turbo  
Cooking Power

**9**  
Pre-Set  
Cooking Modes



## CONTENTS

1.	GETTING TO KNOW YOUR MILA AIR FRYER .....	4
2.	IMPORTANT SAFEGUARDS.....	5
3.	BEFORE USING THE AIR FRYER .....	7
4.	TOUCHSCREEN CONTROL .....	7
	TIMER CONTROL BUTTONS .....	7
	TEMPERATURE CONTROL BUTTONS .....	7
	PRE-SET COOKING MODES.....	7
	REAL TIME DISPLAY .....	7
	FAN INDICATOR.....	7
5.	OPERATING INSTRUCTIONS- A QUICK GUIDE.....	8
6.	MANUAL OPERATION.....	8
7.	PRE-SET COOKING MODES SETTING .....	9
8.	FOOD MENU PRE-SETS.....	10
9.	EASY-ASSIST FUNCTION: PREHEAT .....	10
10.	AIR FRYING COOKING TIPS.....	10
11.	AIR FRYING PRE-PACKAGED FROZEN FOODS.....	11
12.	AIR FRYING CHART .....	11
13.	AIR FRYER MAINTENANCE .....	12
14.	CARE & CLEANING INSTRUCTIONS.....	12
15.	STORING INSTRUCTIONS.....	12
16.	TROUBLESHOOTING .....	13
17.	WARRANTY TERMS & CONDITIONS .....	14
18.	INDEMNITY .....	14
19.	WARRANTY & WARRANTY DISCLAIMER.....	14
20.	LIMITATIONS & LIABILITY.....	15

# 1. GETTING TO KNOW YOUR MILA AIR FRYER

## 1. Whats in the box:

- Airfryer with removable frying basket
- Removable Airflow Tray

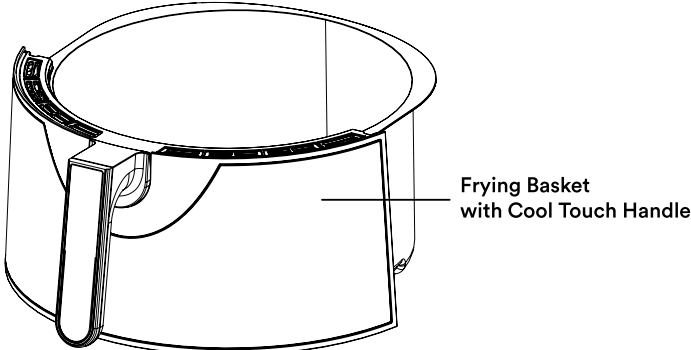
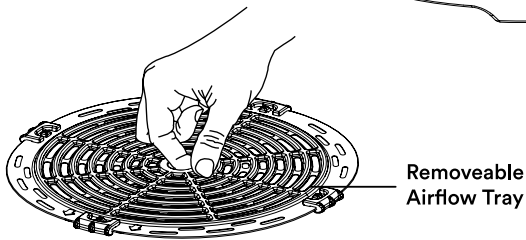
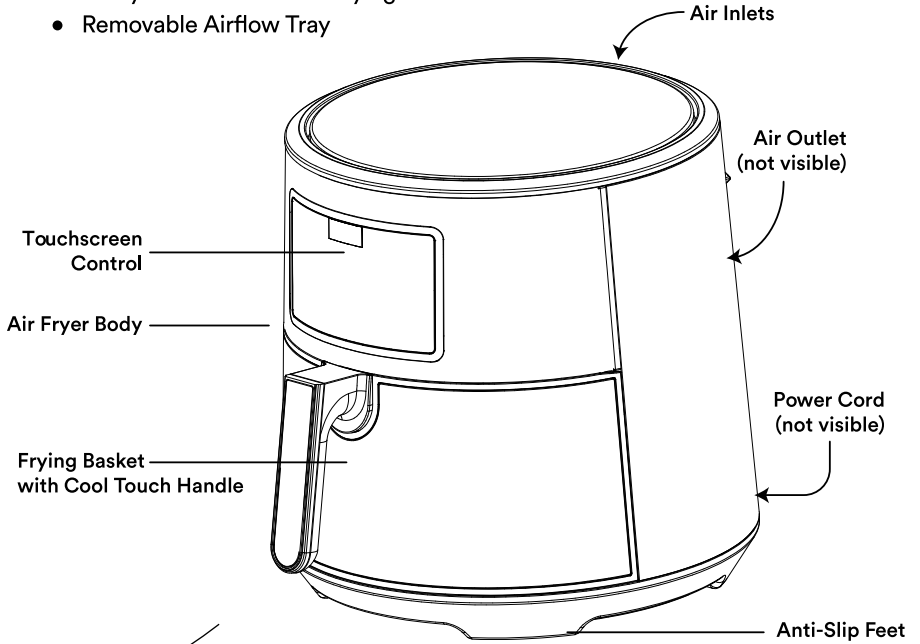

(Product may vary slightly from illustration)

## 2. IMPORTANT SAFEGUARDS

When using electrical appliances, please follow these basic safety precautions:

1. **DO NOT** touch hot surfaces. Use handles, oven mitts or potholders.
2. To protect against electric shock **DO NOT** immerse the cord, plugs, or appliance in water or other liquid.
3. All users of this appliance should read and understand this instruction manual before operating or cleaning this appliance.
4. Unplug the appliance from the power outlet when not in use and before cleaning.
5. Allow to cool before putting on or taking off parts, and before cleaning the appliance.
6. **DO NOT** operate the appliance if it has malfunctioned or has been damaged, including the power cord or plug. If the power cord is damaged, it must be replaced by the manufacturer, its service agent or qualified technician in order to avoid a hazard.
7. The use of accessory attachments not recommended by the appliance manufacturer may cause injuries and void the product warranty.
8. **DO NOT** use outdoors.
9. **DO NOT** let the cord hang over the edge of tables or counters, or touch hot surfaces.
10. **DO NOT** place on or near a hot gas or electric burner, or in a heated oven.
11. **DO NOT** move the appliance while containing hot oil or other hot liquids.
12. **DO NOT** use the appliance for other than intended use.
13. Make sure the removable airflow tray is in place before adding food to be air fried.
14. Make sure the frying basket is locked securely into the front of the Air Fryer, while the Air Fryer is in operation.
15. This appliance is not intended for use by persons (including children) with reduced physical, sensory or mental capabilities, or lack of experience and knowledge, unless they are being supervised or given instruction concerning use of the appliances by the person responsible for their safety.
16. Children should be supervised to ensure that they **DO NOT** play with the appliance.
17. Close supervision is necessary when your appliance is being used near children or infants.
18. This appliance is intended for household use only, it is not warranted for use in a commercial or business application.
19. The air fryer will not operate unless the frying basket is fully closed.
20. After hot air frying, extreme caution must be used when handling the hot frying basket, removable airflow tray, and cooked foods.
21. **DO NOT** use on acrylic or stone surfaces as heat may cause cracks or surface damage. Do not place directly in front of glass splash backs. Leave a minimum of 10cm from the rear of the unit.

22. This appliance generates heat and escaping steam during use. Proper precautions must be taken to prevent the risk of burns, fires, or other injury to persons or damage to property. Keep your face and hands away from heat or steam outlets.
23. This appliance will become hot during operation and retain heat after turning OFF.
24. Always use oven mitts when handling hot materials and allow metal parts to cool before cleaning.
25. **DO NOT** place anything on top of the appliance while it is operating or while it is hot.
26. The cord to this appliance should be plugged into a 220- 240V AC electrical outlet only.
27. If this appliance begins to malfunction during use, pull the frying basket drawer out of the body. Then remove the plug from the wall outlet. **DO NOT** use or attempt to repair the malfunctioning appliance.
28. **DO NOT** leave this appliance unattended during use.
29. Keep the cord out of reach of children and infants to avoid the risk of electric shock and choking.
30. **DO NOT** obstruct the air outlet or air inlets on the back and sides of the Air Fryer with any objects. Avoid escaping steam from the air outlet during air frying.
31. After air frying, make sure to place the frying basket drawer on a flat, heat-resistant surface.
32. Make sure the basket lock is in the locked position when shaking foods for the Air Fryer. To avoid damage to persons or personal property, do not press the basket release button while shaking the frying basket.
33. Hot oil can collect at the base of the drawer. To avoid risk of burns or personal injury, or to avoid oil from contaminating air fried foods, always unlock and remove the frying basket from the drawer before emptying. **NEVER** turn the drawer upside down with the frying basket attached.
34. Over-filling the frying basket may damage the Air Fryer and could result in serious personal injury.
35. **NEVER** move a hot Air Fryer or an Air Fryer containing hot food.
36. **DO NOT** clean with metal scouring pads. Pieces can break off the pad and touch electrical parts, creating a risk of electric shock.
37. This air fryer should not be used to boil water or to deep fry food.
38. The maximum food weight capacity recommended for this air frying basket is 2kg. The basket can also accommodate a cake or pie at up to 22×7cm.
39. During first use, the Air Fryer may emit a slight odor. This is normal and will not affect the flavor or air convection frying.

### 3. BEFORE USING THE AIR FRYER

1. Remove all packing material and labels from the inside and outside of the Air Fryer. Check that there is no packaging underneath and around the frying basket.
2. The Air Fryer is shipped with the frying basket locked inside the air fryer body. Firmly grasp the frying basket handle to open frying basket and place on a flat, clean work area.
3. Wash frying basket and removable airflow tray in hot, soapy water.
4. **DO NOT IMMERSE THE AIR FRYER BODY IN WATER.** Wipe the Air Fryer body with a damp cloth. Dry all parts thoroughly.
5. To ensure the removable airflow tray fits snugly into the frying basket drawer, there are 3 rubber tips attached to the sides of the tray. Before using, check to make sure all 3 rubber tips are in place. If they become separated from the tray, simply slide them onto the tabs as shown. (See FIG 2.)

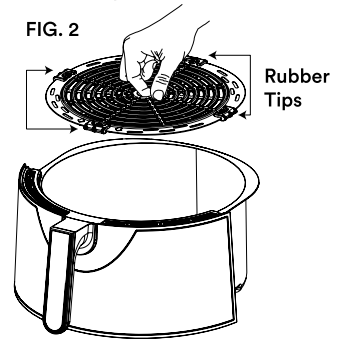

### 4. TOUCHSCREEN CONTROL

#### TIMER CONTROL BUTTONS

Change the cooking time setting by pressing (+) or (-) on the top right of the display.

**NOTE:** Time range 1 - 60 minutes

#### TEMPERATURE CONTROL BUTTONS

Change the cooking temperature setting by pressing (+) or (-) on the top left of the display by 5°C at a time. Keeping the button held down will rapidly change the temperature.

**NOTE:** Temperature control range: 80°C - 200°C.

#### PRE-SET COOKING MODES

There are 9 pre-sets to choose from: Fries, Seafood, Chicken, Fish, Steak, Meat, Roast, Grill and Preheat.









#### REAL TIME DISPLAY

While in operation, the display will alternate between showing the cooking temperature and remaining cooking time.

#### FAN INDICATOR

The flashing white fan icon will appear when the Air Fryer is turned on and for up to 20 seconds after it is turned off.

## 5. OPERATING INSTRUCTIONS- A QUICK GUIDE



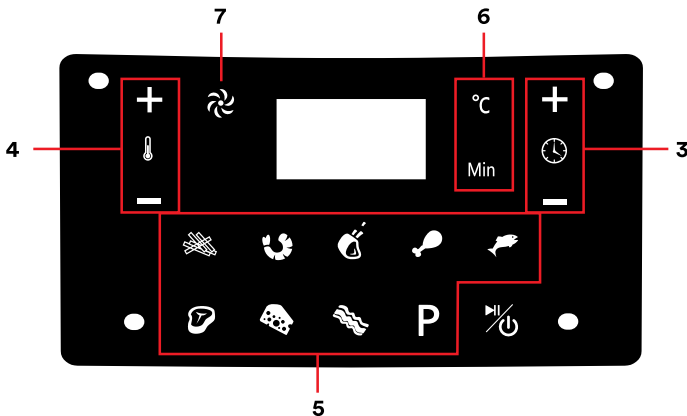





1. Place the Air Fryer on a flat, heat-resistant work area, close to an electrical outlet.
2. Firmly grasp the frying basket handle then remove it from the Air Fryer and place it on a flat, clean surface.
3. Insert the assembled frying basket drawer into the front of the Air Fryer. Always make sure the frying basket drawer is fully closed.
4. Plug the cord into the wall outlet. An audible beep will sound and the  button will illuminate **RED**.
5. To begin, **SHORT PRESS** the **RED**  button.
6. The touchscreen control panel will appear and the  button will turn **WHITE**.
7. The default **TIME** and **TEMP: 15 minutes** and **190°C** and will alternate on the digital display..
8. Press the  button to begin air frying for default time **15 MINUTES** at **190°C**.
9. Short press the  button or remove the frying basket from the drawer to **PAUSE** the Air Fryer. The  button will keep on flashing indicating the Air Fryer is on **PAUSE** and will resume cooking when placed back into the unit.
10. Press & hold the  button for at least 3 seconds to place the Air Fryer in **STANDBY MODE**. The  button will illuminate **RED**. (The **WHITE** fan icon will continue to flash for 20 seconds.) The Air Fryer will enter Stand by Mode after 10 minutes of no activity. This occurs for safety purposes and to save power.











## 6. MANUAL OPERATION

1. To adjust the default air frying **TIME**, press the (+) or (-) on the right side of the control panel to increase or decrease **TIME** in 1 minute increments, from 1 to 60 minutes.
2. To adjust the default air frying temperature, press the (+) or (-) on the left side of the control panel to adjust the default (**190°C**) **TEMP** from **80°C** to **200°C** in 5 degree increments.



3. When the desired **TIME** and **TEMP** appear on the digital display, press the  button to turn the Air Fryer **ON**. The convection fan  will flash when the Air Fryer is in operation. The pre-set **TIME** will begin to count down. **TEMP** and remaining **TIME** will alternate on the digital display.
4. To turn the Air Fryer **OFF** at any time, or to reset the **TIME**, press and hold the  button for at least 3 seconds.  button will illuminate **RED** indicating the Air Fryer is in **STANDBY MODE**.
5. When the remaining **TIME** reaches **00:00**, the  button will illuminate **RED** and the convection fan  will continue to flash for 20 seconds. 5 beeps will sound as the Air Fryer automatically turns **OFF** and goes into **STANDBY** mode.
6. Air frying operation can be paused by short pressing the  button. The  button will start flashing and the fan icon will disappear signifying **PAUSE**. If there is no operation within 10 minutes of the Air Fryer entering **PAUSE** mode, the Air Fryer will go into **STANDBY** mode.

## 7. PRE-SET COOKING MODES SETTING



	FUNCTIONS	TIME (Min)		TEMP (°C)	
		DEFAULT	RANGE	DEFAULT	RANGE
	<b>DEFAULT</b>	15min	1min - 60min	190°C	80°C - 200°C
	<b>FRIES</b>	22min	1min - 60min	200°C	80°C - 200°C
	<b>SEAFOOD</b>	8min	1min - 60min	160°C	80°C - 200°C
	<b>ROAST</b>	25min	1min - 60min	200°C	80°C - 200°C
	<b>CHICKEN</b>	20min	1min - 60min	180°C	80°C - 200°C
	<b>FISH</b>	10min	1min - 60min	200°C	80°C - 200°C
	<b>STEAK</b>	12min	1min - 60min	200°C	80°C - 200°C
	<b>GRILL</b>	10min	1min - 60min	200°C	80°C - 200°C
	<b>MEAT</b>	10min	1min - 60min	200°C	80°C - 200°C
<b>P*</b>	<b>PREHEAT</b>	3min	1min - 60min	200°C	80°C - 200°C

When using the **preheat P** function, please reduce total cooking time by 3 minutes.

Depending on the thickness and/or density of foods, it may be necessary to use a meat thermometer to check cooking progress after pre-set time has expired. If more time is needed, cook at short time intervals until the desired temperature is reached.

## 8. FOOD MENU PRE-SETS

(Fries, Seafood, Chicken, Fish, Steak, Meat, Roast, Grill and Preheat).

1. To use food **MENU** options, simply press the desired food icon.
2. When the desired food menu option icon is illuminated, press the  button to turn the Air Fryer **ON**.
3. Short Press the **RED**  button to exit **STANDBY** mode.
4. All the PRE-SET icons will be illuminated **WHITE** on the display screen.
5. Press the desired food pre-set menu to be cooked.
6. The desired food menu will start flashing and the Air Fryer will start operation with pre-set temperature and time.
7. Both temperature and time interval settings can be changed during operation by pressing the (+) and (-) keys.

The quantity, density & weight of food will alter the total cooking time necessary. Remember, frying smaller batches will result in shorter cooking times and higher food quality. Always check food halfway through cooking time to determine the final cook time.

## 9. EASY-ASSIST FUNCTION: PREHEAT (P)

Save time and make perfect air frying effortless.

1. **PREHEAT:** If a recipe calls for a preheated oven, or, when cooking meats or proteins that benefit from a hot initial sear, use the **PREHEAT P** function.
  - Insert the empty air frying basket/drawer into the body of the Air Fryer.
  - Press the  button to begin.
  - The default **TIME** and **TEMP: 3:00 MINUTES** and **200°C** will alternate on the digital display and within 5 seconds the Air Fryer will begin to Preheat.
  - After 5 beeps, place food into the frying basket, program the Air Fryer to the desired temperature and time manually or by using the pre-set menu.

## 10. AIR FRYING COOKING TIPS

1. Please consult the Air Frying Chart and/or follow food package directions for the suggested **TIME** and **TEMP**.
2. Always pat food dry before cooking to encourage it to brown and to avoid excess smoke.
3. To ensure even cooking / browning, **ALWAYS** open the basket drawer halfway through the cook time and check, turn or shake foods in the frying basket. Some recipes may call for brushed or sprayed oil halfway through cooking. Adjust **TIME** or **TEMP** if needed.

4. Allow cooked foods to rest for at least 5 minutes. Remove the Air Fryer drawer from the machine and place it on a flat, heat resistant surface.
5. Remove air fried foods and place onto a serving tray. Promptly return the frying basket to the drawer and lock it into place.
6. To avoid excess smoke, when cooking naturally high fat foods, such as bacon, chicken wings or sausages, it may be necessary to empty fat from the frying basket drawer between batches.
7. For crispier results, air fry small batches of freshly crumbed foods. Create more surface area by cutting food into smaller pieces. Press crumbs onto food to help it adhere. Refrigerate crumbed foods for at least 30 minutes before frying.
8. Arrange crumbed food in the frying basket so that food is not touching to allow air flow on all surfaces.
9. Spray oils work best. Oil is distributed evenly and less oil is needed.
10. Canola, olive, avocado, coconut, grape seed, peanut, or vegetable oils work well.

## 11. AIR FRYING PRE-PACKAGED FROZEN FOODS

1. It is suggested to use less time than mentioned on the packaging. Always check food halfway through cooking time to adjust **TIME** and **TEMPERATURE** if required.

## 12. AIR FRYING CHART

Times are estimated and based on average sizes and weights. Always use a cooking thermometer to ensure that meat, poultry and fish are cooked thoroughly before serving.

Frying smaller batches will result in shorter cooking times and higher food quality. Adjust air frying temperatures and times as necessary to suit your taste.

Unless food is pre-packaged and pre-oiled, for browned and crispy results, all foods should be lightly oiled before air frying.

FOOD	TEMP	AIR FRY TIME	ACTIONS
Root Vegetables	190°C	15-20 minutes	Toss with oil shake 3x
Asparagus	190°C	7-9 minutes	Spray with oil, shake 2x
Green Beans, Sugar Snap Peas	190°C	7-9 minutes	Spray with oil, shake 1x
Broccoli	190°C	5-7 minutes	Spray with oil, shake 3x
Brussels Sprouts, halved	190°C	8-10 minutes	Spray with oil, shake 2x
Butternut Squash, seeded	190°C	15 minutes	Spray with oil, shake 3x
Fennel, fresh, chopped	190°C	7-9 minutes	Spray with oil, shake 2x
Fried Sweet Potato Fries	200°C	13-15 minutes	Spray with oil, shake 3x
French Fries, Russet Potatoes, 2-3	200°C	12 minutes	Spray with oil, shake 3x
Meat, Roast, Chops	180°C	25 minutes	Rub or spray with oil, add seasoning, turn over & test for doneness

Rib-eye Steaks	180°C	Preheat +6 minutes Preheat +10 minutes Preheat +14 minutes	Rub or spray with oil, add seasoning, turn over & test for doneness, rest 15 minutes - check at 12 minutes, rest 15 minutes
Hamburgers	175°C	Preheat +3-6 minutes	Spray with oil, add seasoning, turn over test for doneness
Chicken Wings	180°C	20 minutes	Spray with oil, shake 2x, test for doneness
Chicken Tenders/Fingers, boneless	180°C	18-20 minutes	Spray with oil, shake 1x
Chicken Pieces with bone	180°C	20-30 minutes	Spray with oil, turn over, test for doneness
Fish Fillet (fresh, thawed, battered)	200°C	10 minutes	Spray with oil, turn over, test for doneness
Shrimp (thawed, battered)	160°C	8 minutes	Spray with oil, turn over, shake

### 13. AIR FRYER MAINTENANCE

This appliance requires little maintenance. It contains no user-serviceable parts. Any servicing requiring disassembly other than cleaning must be performed by a qualified appliance repair technician.

### 14. CARE & CLEANING INSTRUCTIONS

**WARNING!** Allow the Air fryer to cool fully before cleaning.

1. Unplug the Air Fryer. Remove the frying basket. Make sure the frying basket and removable airflow tray have cooled completely before cleaning. Use the center hole of the removable airflow tray to lift it up and out of the frying basket.
2. Wash the frying basket and removable airflow tray in hot soapy water. Do not use metal kitchen utensils or abrasive cleansers or cleaning products as this may damage the non-stick coating.
3. The frying basket and removable airflow tray are dishwasher-safe. For best results, place in the top rack of your dishwasher to clean.
4. Wipe the air fryer body with a soft, non-abrasive damp cloth to clean.

### 15. STORING INSTRUCTIONS

1. Make sure the Air Fryer is unplugged and all parts are clean and dry before storing.
2. Never store the Air Fryer while it is hot or wet.
3. Lock the frying basket into the drawer, and store inside the Air Fryer body.
4. Store the Air Fryer in its box or in a clean, dry place.

## 16. TROUBLESHOOTING

PROBLEM	POSSIBLE CAUSE	SOLUTION
The Air Fryer doesn't work	<ul style="list-style-type: none"> <li>The Air Fryer is not plugged in</li> <li>The Air Fryer has turned itself off</li> </ul>	<ul style="list-style-type: none"> <li>Plug the cord into the wall outlet</li> <li>To begin, press the  button</li> <li>Make sure the frying basket/drawer is assembled correctly and fully inserted into the Air Fryer body</li> </ul>
Food not cooked	<ul style="list-style-type: none"> <li>The Frying basket is overloaded</li> </ul>	<ul style="list-style-type: none"> <li>Fry smaller batches of food</li> <li>Shake foods 2 or 3 times during the cooking process</li> <li>Increase <b>TEMP</b></li> <li>Increase <b>AIR FRY TIME</b></li> </ul>
Food is not fried evenly	<ul style="list-style-type: none"> <li>The Frying basket is overloaded</li> </ul>	<ul style="list-style-type: none"> <li>Fry smaller batches of food</li> <li>Apply a light even coat of spray oil to food before frying</li> <li>Shake foods <b>2 OR 3 TIMES</b> during the cooking process</li> </ul>
Frying basket / drawer won't slide into the Air Fryer body properly	<ul style="list-style-type: none"> <li>The Frying basket is overloaded</li> </ul>	<ul style="list-style-type: none"> <li>Fry smaller batches of food</li> <li>Air Fryer will not turn <b>ON</b> until the frying basket/drawer is assembled correctly and fully inserted properly into the Fryer body</li> </ul>
White smoke coming from the Air Fryer	<ul style="list-style-type: none"> <li>The Air Fryer is overloaded with oil</li> <li>The Frying basket and drawer have not been cleaned</li> </ul>	<ul style="list-style-type: none"> <li>When frying very oily foods, such as bacon, it may be necessary to drain the frying basket more frequently</li> <li>Clean the frying basket and drawer after each use</li> </ul>
Fresh fries are not fried evenly	<ul style="list-style-type: none"> <li>The Frying basket is overloaded</li> </ul>	<ul style="list-style-type: none"> <li>Soak, rinse and fully dry potatoes before frying</li> <li>Use fresh, firm potatoes</li> </ul>
Fries are not crispy	<ul style="list-style-type: none"> <li>Raw fries have too much water</li> </ul>	<ul style="list-style-type: none"> <li>Use a clean kitchen towel to wrap and dry cut potato fries thoroughly before adding oil</li> <li>Cut potato fries smaller</li> <li>Shake and spray potato fries frequently</li> </ul>

## 17. WARRANTY TERMS & CONDITIONS

Our goods come with guarantees that cannot be excluded under the Australian Consumer Law. You are entitled to a replacement or refund for a major failure and for compensation for any other reasonably foreseeable loss or damage. You are also entitled to have the goods repaired or replaced if the goods fail to be of acceptable quality and the failure does not amount to a major failure.

This warranty is provided in addition to your rights under the Australian Consumer Law. Directed Electronics Australia Pty Ltd (Directed Electronics) warrants that this product is free from defects in material and workmanship for a period of 12 months from the date of purchase or for the period stated on the packaging. This warranty is only valid where you have used the product in accordance with any recommendations or instructions provided by Directed Electronics.

This warranty excludes defects resulting from alterations of the product, accident, misuse, abuse or neglect. In order to claim the warranty, you must return the product to the retailer from which it was purchased or if that retailer is part of a National network, a store within that chain, along with satisfactory proof of purchase. The retailer will then return the goods to Directed Electronics.

Directed Electronics will repair, replace or refurbish the product at its discretion. The retailer will contact you when the product is ready for collection. All costs involved in claiming this warranty, including the cost of the retailer sending the product to Directed Electronics, will be borne by you.

**Email:** [info@milahome.com.au](mailto:info@milahome.com.au)

**Phone:** +61 03 8331 4800

## 18. INDEMNITY

You agree to defend, indemnify and hold harmless Mila from and against any and all claims, proceedings, injuries, liabilities, losses, costs and expenses (including reasonable legal fees), including but not limited to, claims alleging negligence, invasion of privacy, copyright infringement and/or trademark infringement against Mila services, relating to or arising out of your breach of any provision of these terms, your misuse of the Mila services, or your unauthorized modification or alteration of products or software.

## 19. WARRANTY & WARRANTY DISCLAIMER

Mila has a limited warranty whereby Mila warrants to you and only to you that Mila products will be free from defects in materials and workmanship for one (1) year from the date of your purchase of the Mila products (unless a longer warranty period is required by law).

The specifics of this Mila limited warranty are at <https://www.milahome.com.au/warranty>

Mila also assumes no responsibility for and shall not be liable for any damages caused by misuse of the product or failure to follow the instructions provided.

Other than the above product warranty for the Mila products, Mila and its suppliers disclaim all warranties of any kind, whether express, implied, or statutory, regarding

the Mila equipment. Including any implied warranty of title, merchantability, fitness for a particular purpose, or non infringement of third party rights. Because some jurisdictions do not permit the exclusion of implied warranties, the last sentence of this section may not apply to you. Mila hereby further expressly disclaims all liability for any claims for service failures that are due to normal product wear, product misuse, abuse, product modification, improper product selection or your non-compliance with any and all applicable federal, state or local laws. This warranty and warranty disclaimer give you specific legal rights, and you may have other rights that vary by state, province, or country. Other than as permitted by law, Mila does not exclude, limit or suspend other rights you have, including those that may arise from the nonconformity of a sales contract. For a full understanding of your rights you should consult the laws of your state, province, or country. For our Australian customers: please note that this warranty is in addition to any statutory rights in Australia in relation to your goods which, pursuant to the Australian Consumer Law, cannot be excluded.

## **20. LIMITATIONS & LIABILITY**

Mila liability for damages, especially for breach of duty or obligation, delay in performance, non-performance, or malperformance shall be precluded, except when these are due to negligent breaches of any significant contractual duty or obligation on the part of Mila. Any liability for negligence is limited to direct losses usually and typically foreseeable in such case. Should the claim for damages be based on willful or grossly negligent breach of contractual duty or obligation on the part of Mila, the preclusion and limitation of liability mentioned in the preceding sentences will not apply. The preceding preclusion and limitation of liability will also not apply to claims for damages arising out of loss of life, bodily injury or health impacts for which Mila may be liable, or for non-contractual liability.

Some states and countries do not allow the exclusion or limitation of incidental or consequential damages, so the above limitation or exclusion may not apply to you. Additionally, this provision is not intended to limit Mila's liability in the event of Mila's willful or intentional misconduct.

# mila

[www.milahome.com.au](http://www.milahome.com.au)  
[www.milahome.co.nz](http://www.milahome.co.nz)

